

6

5

4

3

2

1

D

D

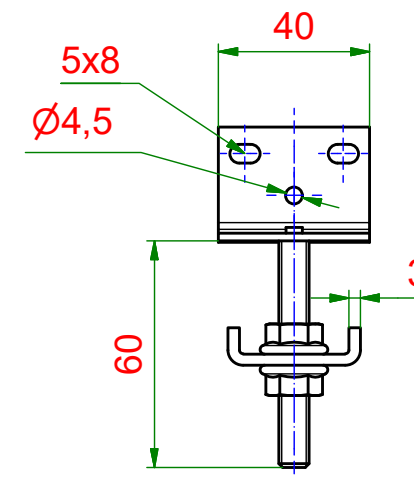
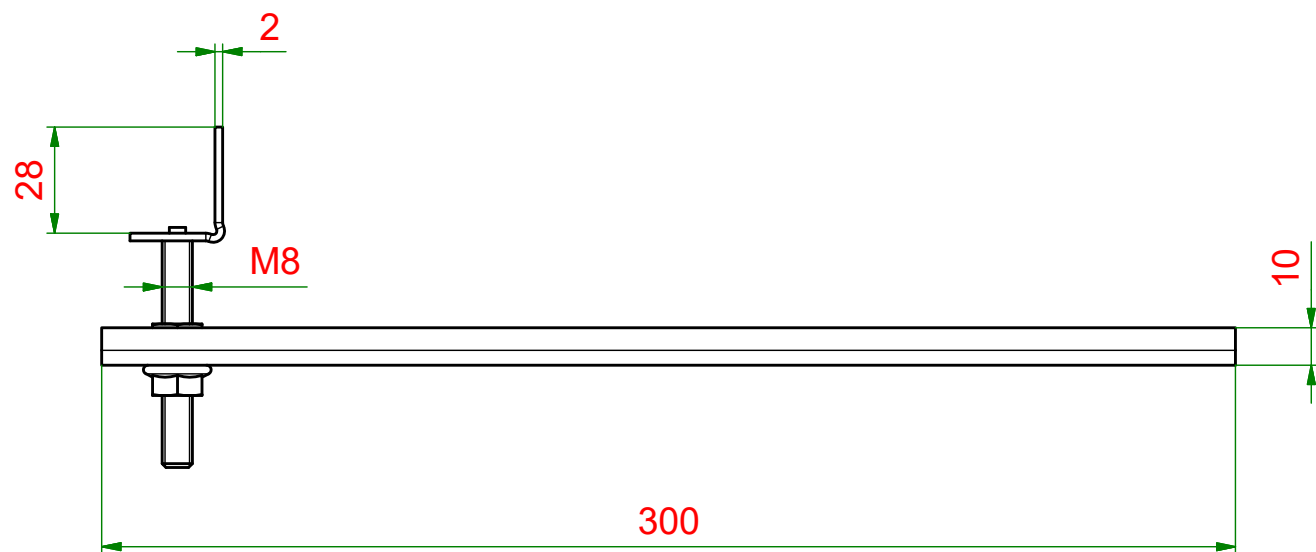

C

C

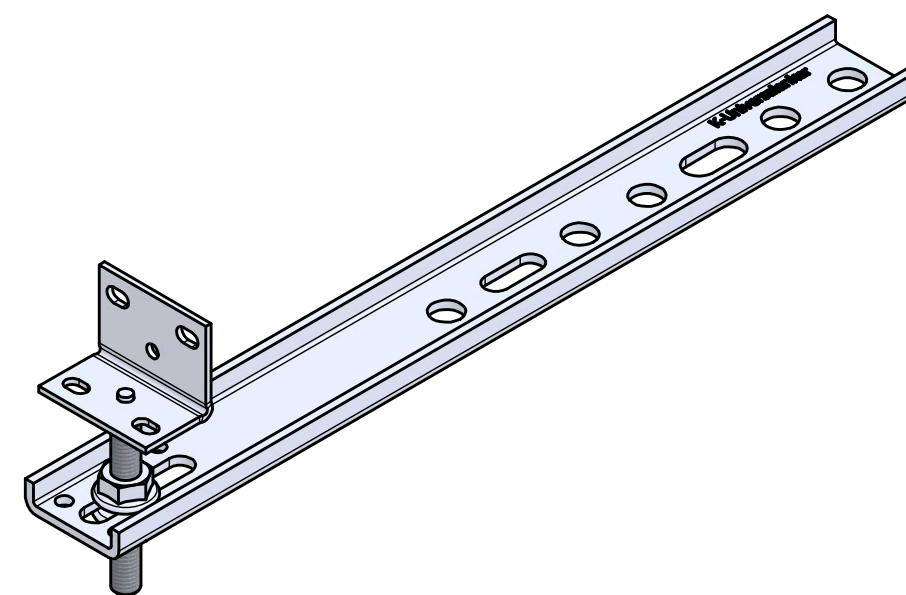
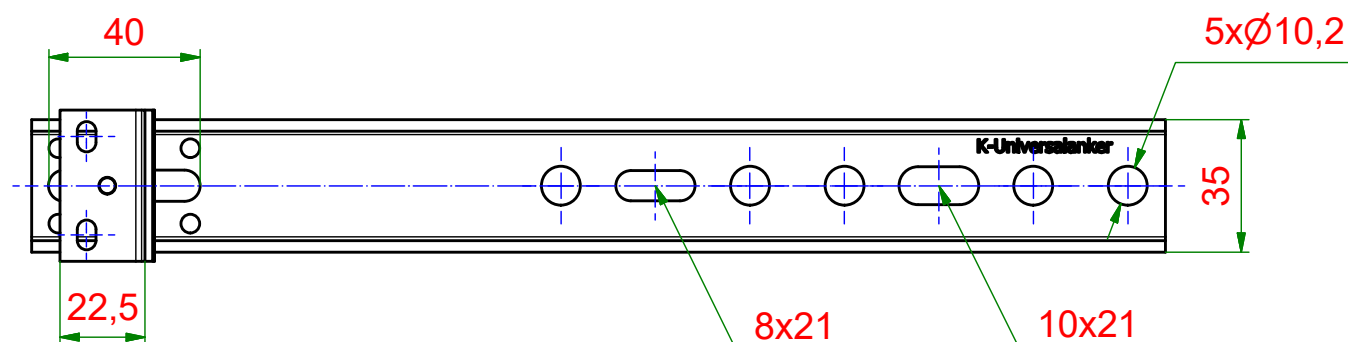

B

B

A

A

6

5

4

3

2

1

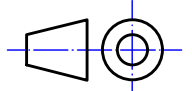
 <p>KNELSEN Entwicklung und Herstellung</p>			Material: verzinkter Stahl		
			Maßstab: 1 : 2	Masse: 0,4 kg	
	Erstellt	Datum	Name	Titel, Beschreibung	
	Genehmigt			WU-300x3,0-60 WU-Anker	
			Bauteilnummer / Zeichnungsnummer	Blatt 1	
Knelsen GmbH Am Schlinge 26 33154 Salzkotten Tel.: 05258 / 93766-95 Fax: 05258 / 93766-97 www.knelsen-gmbh.de info@knelsen-gmbh.de			405155	A3	
			Schutzvermerk nach DIN ISO 16016 beachten		